

13. Josiah (2 Kings 22:1—23:23)

He did what was right in the LORD'S eyes. (2 Kings 22:2)



PLAN

Session Outline

1. Gather

Greeting
Josiah
See the Sanctuary
Transition to Explore

2. Explore

Sacred Conversation
Hear and See the Bible Story
Interact with the Bible Story
Say the Bible Verse
Transition to Respond

3. Respond

Kings Crown
Hidden Scroll Hunt
Loving God,
Loving Neighbor
Transition to Bless

4. Bless

Inviting
Praising
Blessing
At Home with God

Supplies

Basic Supplies: CD player | DVD player | Projector or screen | Television | Craft glue | Crayons | Markers | Offering basket | Paper | Pencils | Scissors | Tape

Gather: Bell | Carpet squares

Explore: Bell

Respond: Bell | Candle | Carpet squares | Decorative supplies | Multipurpose lighter

Bless: No additional supplies

Before You Teach

The leader we read about today is Josiah, one of the few kings of Israel who was faithful to God. After King David, Israel did not fare well when it came to kings. King Solomon, David's son, began well, asking God for wisdom. But he turned out to be self-serving and oppressive. As a result of his unfaithfulness, the kingdom was divided into two parts: Israel and Judah.

After the split, the kings in the Northern Kingdom (Israel) were all failures. Judah didn't fare much better. A few of Judah's kings tried to do right by God, such as Asa, Jehoshaphat, and Hezekiah. But even these kings did not uphold the laws of the Torah.

Then along came Josiah. Josiah was only eight years old when he became king, an age at which children today would be in second or third grade. Josiah received high praise from the writer of 2 Kings. "He did what was right in the LORD's eyes, and walked in the ways of his ancestor David—not deviating from it even a bit to the right or left" (2 Kings 22:2).

One of the things Josiah did during his reign was to order that the Temple be restored. During the renovation of the Temple, the high priest, Hilkiah, discovered an "instruction scroll" that had been hidden away. Upon hearing the contents of the scroll read, Josiah was overcome with grief because he realized the people had not been following the law.

King Josiah read to the people the discovered scroll and made a covenant with God to follow God's commandments. Josiah urged the people once again to be faithful to God. Josiah then ordered that all religious objects made for Baal to be removed from the Temple, and he set out to desecrate all the shrines to false gods in the areas around Jerusalem. Josiah also ordered the people to begin celebrating Passover again as described in the discovered scroll. Passover had not been celebrated since the judges ruled over Israel. King Josiah showed many qualities of a good leader.

13. Josiah (2 Kings 22:1—23:23)

He did what was right in the LORD'S eyes. (2 Kings 22:2)



GATHER

Greeting

Before class: Display your choice of attendance chart (Class Kit—pp. 16-17 or pp. 18 & 15).

- Play “Be a Leader” (Annual Music CD).
 - Welcome and greet each child as he or she enters the room.
 - Indicate location of the offering basket.
 - Help children mark their attendance inside the building on the Community Attendance Chart (opt.).
-

A—Josiah (Activity Sheet)

Before class: Obtain Activity Sheets (Session 13).

- Distribute “To Be King”/“Scroll Search” (pp. 27-28).
 - Encourage the children to follow the journaling prompt and complete the activities.
-

OR

B—See the Sanctuary (Sensory)

- Take a class trip to the church sanctuary. If possible, let the children take turns being the line leader on the walk there and back.
 - When you arrive in the worship space, help the children notice the architecture, furniture, worship elements, and so forth.
 - Return to the Sunday-school space. Invite the children to write or draw about they saw.
 - Invite willing volunteers to share.
-

Transition to Explore

Before class: Obtain bell and carpet squares.

- Ring the bell to acknowledge that it is time to transition.
- Direct the children to choose carpet squares (or equivalent items), then sit in a circle on the floor.

13. Josiah (2 Kings 22:1—23:23)

He did what was right in the LORD'S eyes. (2 Kings 22:2)

EXPLORE

Sacred Conversation

- Ask a few wondering questions.

ASK: I wonder:

- What made you laugh this week?
 - How did you help someone this week?
 - What are you grateful for?
 - Was there a difficult part of your week, and what made it better?
 - Where did you see God this week?
-

Hear and See the Bible Story

Before class: Prepare television and DVD player.

- Read the Bible story together (*CEB Deep Blue Kids Bible—2 Kings 22:1—23:23*).
- Watch the Deep Blue Adventure DVD Session 13.

ASK: When have you been a leader?

Interact with the Bible Story

Before class: Obtain Bible Story Sheets (Session 13).

- Distribute the Bible Story Sheets and draw attention to Bible Story Retelling (p. 1).
 - Assign the role of Narrator, then present “Josiah.”
-

Say the Bible Verse

Before class: Display Poster: Unit 3 Bible Verse (Class Kit—pp. 14 & 19). Review Unit 3 sign language (Leader Guide—p. 93).

- Recite the Bible verse, “He did what was right in the LORD’S eyes” (2 Kings 22:2).
 - Invite the children to say and sign the Bible verse with you.
-

Transition to Respond

Before class: Obtain bell.

- Ring the bell, then invite the children to put away their carpet squares.

13. Josiah (2 Kings 22:1—23:23)

He did what was right in the LORD'S eyes. (2 Kings 22:2)

RESPOND

A—King's Crown (Art)

Before class: Obtain decorative supplies. Photocopy "King's Crown" (Leader Guide—p. 84), one per child.

- Distribute the photocopies of "King's Crown."
- Invite the children to decorate and assemble their crowns. Encourage them to wear the crowns.

SAY: You are never too young to be a leader.

OR

B—Hidden Scroll Hunt (Game)

Before class: Obtain nine paper slips. Write each word of the Bible verse on a slip. Roll the slips to look like scrolls. Hide around the Sunday-school space.

SAY: We are going to hunt for a scroll. However, there is more than one scroll hidden in the room. You must work together to find the scrolls, then arrange the message.

- Encourage the children to find the scrolls and to put together the Bible verse.

Loving God, Loving Neighbor

Before class: Obtain Map 6: Deep Blue Shores (Class Kit—p. 8) and Figures/Pieces: Deep Blue Shores Map 6 (Class Kit—p. 25).

- Display the Deep Blue Shores Map 6 on the floor or table. While the children interact with the map and figures, talk about Armen.

SAY: Armen is an exchange student from Armenia. He might be young, but he can learn about new places and make new friends at any age.

ASK: What is something new that you have learned? What is it like to meet someone new?

Transition to Bless

Before class: Obtain bell, candle, multipurpose lighter (or battery-operated candle), carpet squares.

- Ring the bell to signal transition.
- Direct the children to each choose a carpet square, then sit in a circle on the floor.

13. Josiah (2 Kings 22:1—23:23)

He did what was right in the LORD'S eyes. (2 Kings 22:2)

BLESS

Inviting

Before class: Continue to display Poster: Unit 3 Bible Verse (Class Kit—pp. 14 & 19) where it is easily accessible for children. Obtain Poster Pieces: Unit 3 Bible Verse (Class Kit—p. 27).

- Gather the children around the Bible-verse poster.
- Display the poster pieces.
- Invite a child to attach to the poster the “scroll” poster piece.

PRAY: Dear God, help me to be a leader. Amen.

Praising

Before class: Obtain CD player and Deep Blue Song Sheets.

- Distribute the song sheets for “Be a Leader” (Annual Music CD).
 - Sing the song “Be a Leader” (Annual Music CD).
 - Sign the Bible verse (Leader Guide—p. 93).
 - Collect the song sheets and store until the next session.
-

Blessing

- Direct the children to be seated in their chairs and form a circle.
 - Working around the circle, invite a child to stand, say, “I am a leader,” and remain standing. Move to the next child.
 - Let the children continue to stand until all are standing.
 - Invite them to say together, “We are leaders for God!”
-

At Home with God

ASK: What is one thing that you learned today? Can you share with your family what you learned?

- Send home with each child Bible Story Sheets—Session 13 leaflet.

13. Josiah (2 Kings 22:1-23; 23)

He did what was right in the LORD'S eyes. (2 Kings 2:22)

King's Crown

1. Cut out each of the three crown pieces.

Crown center

Left band

Right band

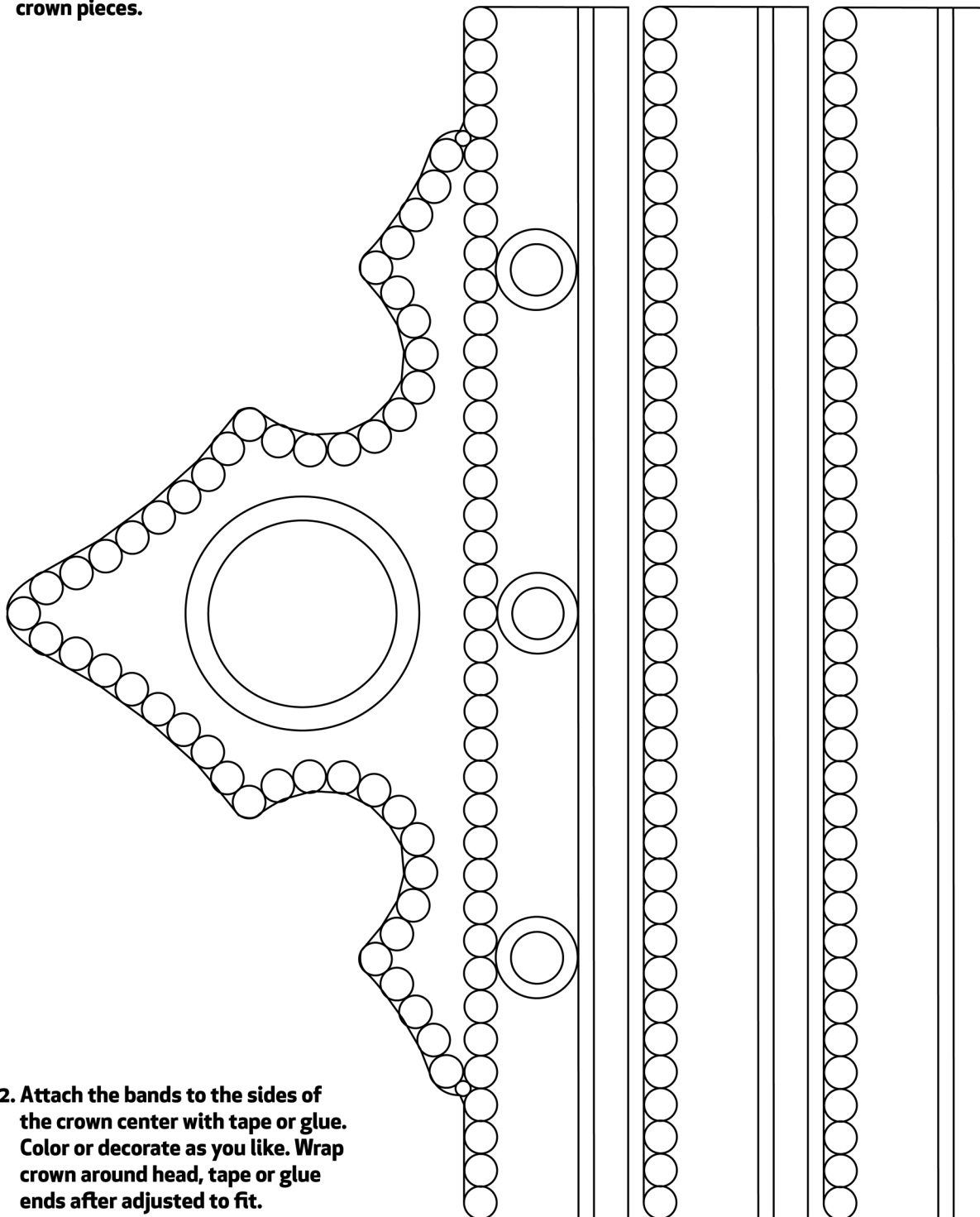

2. Attach the bands to the sides of the crown center with tape or glue. Color or decorate as you like. Wrap crown around head, tape or glue ends after adjusted to fit.